



YLV, DIVIDED REVERSE “Y” BLADE LOUVERS

90 Minute Fire-Rated Steel Louvers

**IN STOCK
FOR IMMEDIATE SHIPPING**

- ▶ For use in Fire Rated Door Applications under Positive and Neutral Pressure Intertek Testing Certification in Compliance to NFPA 252 (2000), UL 10C (2009), NFPA 252 (2012), CSI CIDE 89000 Louvers & Vents
- ▶ 18 Gauge Cold Rolled Steel Frame and Blades
- ▶ Mitered Welded Corner Frame Construction
- ▶ Divided Row “Y” Blades Spaced at 1” Increments with Blocked Vision Design
- ▶ Counter Sunk Mounting Holes with Screws for each Side of the Door
- ▶ Minimum Door Size Thickness: 1 3/8”
- ▶ Baked on Powder Coat Finish.
- ▶ **Color: Standard Bronze (BZ).**
- ▶ Fasteners: Phillips Head Screws # 8 x 3/4”

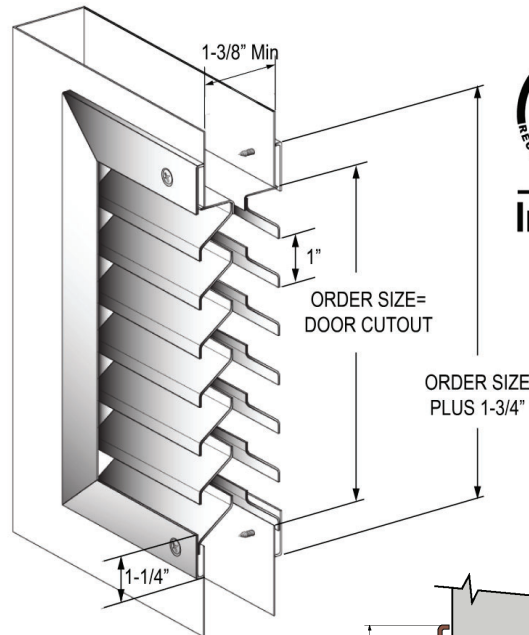

ITEM #	SIZES (DOOR CUTOUT)	PCS / CTN
YLV1212	12" x 12"	1
YLV1812	18" x 12"	1
YLV1818	18" x 18"	1
YLV2412	24" x 12"	1
YLV2424	24" x 24"	1
Shaded Items are Non-Fire Rated.		

See Lites & Louvers Intertek Certification for detailed information on Fire Ratings.
Or visit: <http://www.cal-royal.com/pdf/litescertification.pdf>

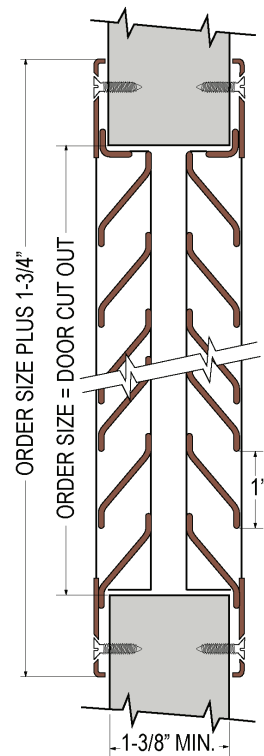

Optional Aluminum Screen
Aluminum Insect (prefix FA)
Ex. UAYLV1212