

LOUVERS

FLLV, ADJUSTABLE FUSIBLE LINK LOUVERS

90 Minute Fire-Rated Steel Louvers

**IN STOCK
FOR IMMEDIATE SHIPPING**

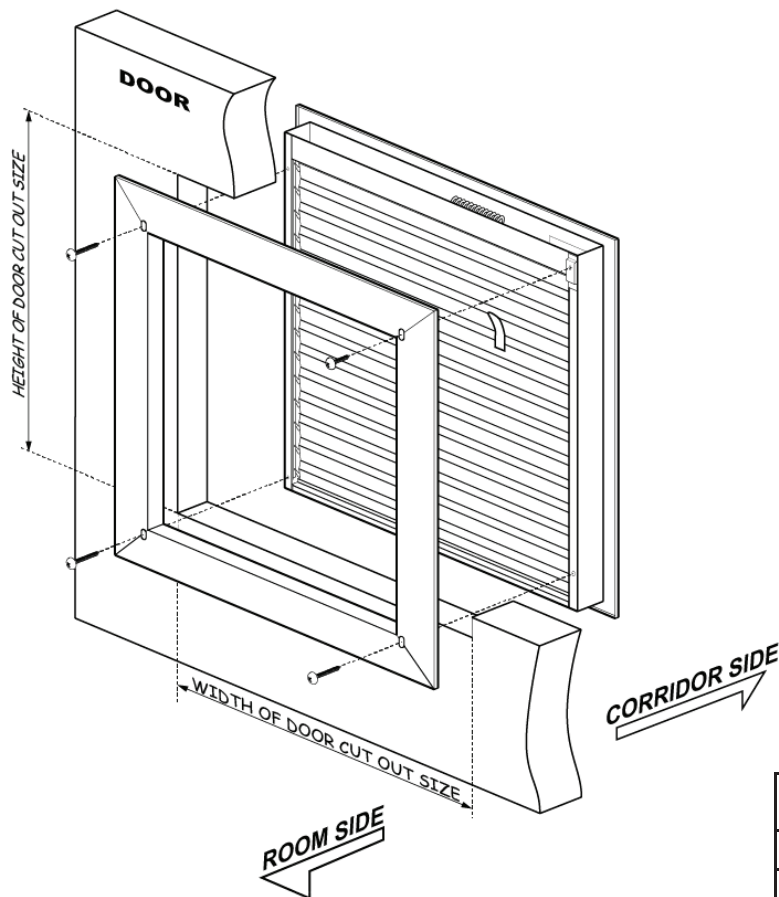

- ▶ For use in Fire Rated Door Applications under Positive and Neutral Pressure Intertek Testing Certification in Compliance to NFPA 252 (2000), UL 10C (2009), NFPA 252 (2012), CSI Code 089000 Louvers & Vents
- ▶ Fusible Link Design Temperature 165°F Max
- ▶ 16 Gauge Cold Rolled Steel Frame and Blades
- ▶ Mitered Welded Corner Frame Construction
- ▶ Free Flow Area: 45% Free
- ▶ 1 9/16" Deep Louver Assembly
- ▶ Cadmium Plated Steel Rivets
- ▶ Cadmium Plated Steel Tension Spring
- ▶ Door Size Thickness: 1 3/4" Only
- ▶ Baked on Powder Coat Finish
- ▶ **Color: Standard Bronze (BZ)**
- ▶ Fasteners: 3 x 3/4" LG & 1 x 1/2" LG

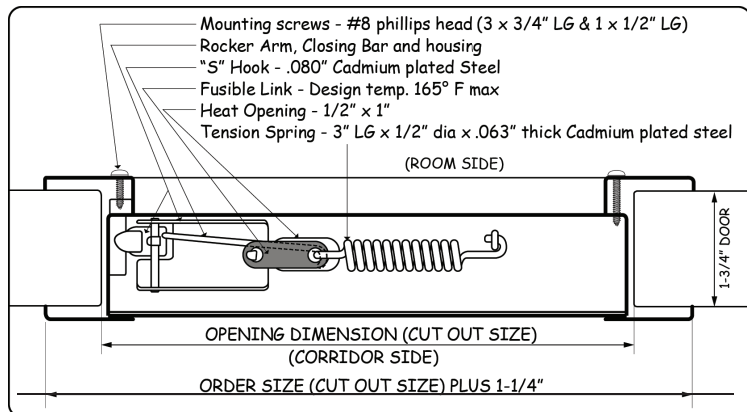

ITEM #	SIZES (DOOR CUTOUT)	PCS /CTN
FLLV1212	12" x 12"	1
FLLV1224	12" x 24"	1
FLLV1812	18" x 12"	1
FLLV1818	18" x 18"	1
FLLV1824	18" x 24"	1
FLLV2412	24" x 12"	1
FLLV2418	24" x 18"	1
FLLV2424	24" x 24"	1

Optional Aluminum Screen
 Unframed Aluminum Insect (prefix UA)
 Ex. UAFLLV1212
 Framed Aluminum Insect (prefix FA)
 Ex. FAFLLV1212