

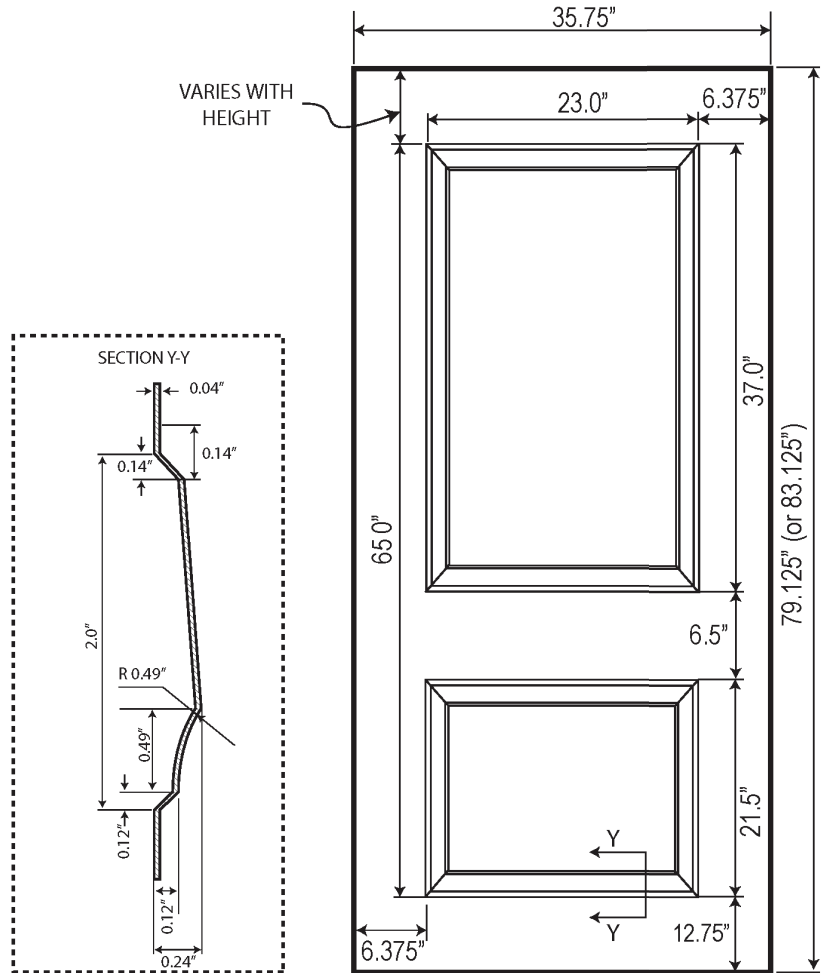

1900 Series 2-Panel Doors 8'0

STOCK REVERSIBLE SEAMLESS POLYSTYRENE DOORS 18 GAUGE

- Includes closer reinforcement, fire label WHI 3HR Positive Pressure **(S)** Smoke label.
- 2 Panel STC rating
18 Gauge STC 28
R value 5.24
U value 0.31
- Meets or Exceeds Standards for ANSI 250.4 and 250.8
- Full Body Polysterene Core
- Non-Handed Design



ITEM #	SIZE	TYPE/GAUGE	PREP
1966	3080	18	C
1967			MB
1968			BR
GALVANIZED			
*G1966	3080	18	C
*G1967			MB
*G1968			BR

*FACTORY ORDER ONLY



1900 Series 2-Panel Doors

STOCK REVERSIBLE SEAMLESS POLYSTYRENE 2-PANEL DOORS

18 GAUGE

- Includes closer reinforcement, fire label WHI 3HR Positive Pressure, **(S)** Smoke label.
- 2 Panel ATC rating
- 18 Gauge STC 28
- R value 5.24
- U value 0.31

ITEM#	SIZE	TYPE/GAUGE	PREP
STOCK			
1900	3068	18	C
1901			MB
1903			C/DL 5 1/2" C.T.C
NON-STOCK			
1902	3068	18	BR
STOCK			
1905	3070	18	C
1906			MB
NON-STOCK			
1907	3070	18	BR
1908			C/DL 5 1/2" C.T.C
STOCK ONLY IN PA			
*G1905	3070	18	C

* GALVANIZED

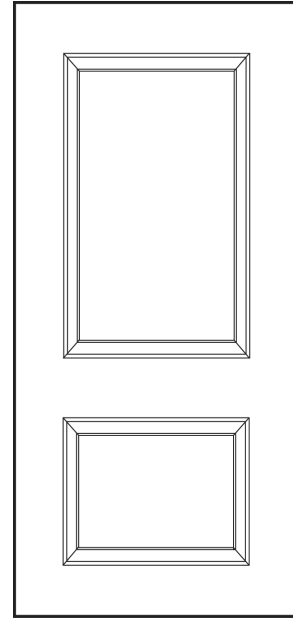

NON-STOCK			
ITEM#	SIZE	TYPE/GAUGE	PREP
1910	3068	18	C
1911			MB
1912			BR
1913			C/DL 5 1/2" C.T.C
1914	3070	18	C
1915			MB
1916			BR
1917			C/DL 5 1/2" C.T.C

