



# 1800 Series Flush Doors

## STOCK REVERSIBLE SEAMLESS POLYSTYRENE FLUSH DOORS

### 18 GAUGE

- Includes closer reinforcement, fire label WHI 3HR Positive Pressure  Smoke label.
- STC rating 26, R value 5.24, U value 0.31
- Other locations and sizes are available.

### DOOR MANUFACTURERS CHART

<b>CE</b>	Ceco Location (non handed)	<b>DE</b>	Dean Steel Location (non handed)
<b>CU</b>	Curries Location (non handed)	<b>REP</b>	Republic Location (non handed)
<b>ME</b>	Mesker Location, use DE Location	<b>PIO</b>	Pioneer Location, available at PA warehouse only (non handed)

ITEM#	SIZE	PREP
1801	2068	C
1802		MB
1805		BR
1835	2070	C
1836		MB
1838		BR
1851	2080	C
1857		BR
1810	2468	C
1811		MB
1875	2470	C
1876		MB
1807	2668	C
1808		MB
1809		BR
1891	2670	C
1892		MB
1893		BR
1828	2680	C
1829		MB
1825	2868	C
1826		MB
1894	2870	C
1895		MB
1869	21068	C
1870		MB
1871		BR
1897	21070	C
1898		MB
1899		BR
1886	21080	C
1889		BR

ITEM#	SIZE	PREP
1813	3068	C
1815		C/DL 4" CTC
1816		C/DL, ADA 7-11/16" CTC
1817		C/DL, 5-1/2" CTC
1818		MB
1824		BR
1413		T
1839	3070	C/DL, ADA 7-11/16" CTC
1840		C
1841		C/DL, 5-1/2" CTC
1843		C/DL, 4" CTC
1844		MB
1847		BR
1440	T	
1848	3072	C
1845		MB
1846		BR
1863	3080	C
1862		MB
1864		BR
1819	3468	C
1820		MB
1806		BR
1821	3470	C
1814		MB
1830	3668	C
1831		MB
1832		BR
1849	3670	C
1850		MB
1852		BR
1860	3680	C
1861		MB

**CONTINUED NEXT PAGE**



# 1800 Series Flush Doors

## STOCK REVERSIBLE SEAMLESS POLYSTYRENE FLUSH DOORS

### 18 GAUGE

- Includes closer reinforcement, fire label WHI 3HR Positive Pressure  Smoke label.
- STC rating 26, R value 5.24, U value 0.31
- Other locations and sizes are available.

### DOOR MANUFACTURERS CHART

<b>CE</b>	Ceco Location (non handed)	<b>DE</b>	Dean Steel Location (non handed)
<b>CU</b>	Curries Location (non handed)	<b>REP</b>	Republic Location (non handed)
<b>ME</b>	Mesker Location, use DE Location	<b>PIO</b>	Pioneer Location, available at PA warehouse only (non handed)

CONTINUATION		
ITEM#	SIZE	PREP
1834	3868	C
1837		MB
1842		BR
1853	3870	C
1858		MB
1856		BR
1872	4068	C
1873		MB
1874		BR
1854	4070	C
1855		MB
1859		BR
1865	4080	C
1866		MB
1868		BR
GALVANIZED		
1880	3068	C
1881		MB
1882		BR
1884	3070	C
1887		MB
1890		BR
1885		T
GALVANIZED CURRIES LOCATION DOORS		
CUG1824	3068	BR
CUG1840	3070	C
CUG1844		MB
CUG1847		BR
GALVANIZED CECO LOCATION DOORS		
CEG1813	3068	C
CEG1818		MB
CEG1824		BR
CEG1840	3070	C
CEG1844		MB
CEG1847		BR

ITEM#	SIZE	PREP
CECO LOCATION DOORS		
CE1813	3068	C
CE1818		MB
CE1840	3070	C
CE1844		MB
CE1847		BR
CURRIES LOCATION DOORS		
CU1813	3068	C
CU1818		MB
CU1824		BR
CU1840	3070	C
CU1844		MB
CU1847		BR
CU1854	4070	C
CU1855		MB
DEAN STEEL LOCATION DOORS		
DE1813	3068	C
DE1818		MB
DE1824		BR
DE1840	3070	C
DE1844		MB
DE1847		BR
REPUBLIC LOCATION DOORS		
**REP1813	3068	C
**REP1818		MB
**REP1824		BR
REP1840	3070	C
REP1844		MB
REP1847		BR

\*\*Use 1813, 1818, 1824 for REP1813, REP1818 and REP1824 respectively.  
Add prefix "N" for New Republic Door Location



# 1800 Series Seamless Doors with Cutouts

## STOCK REVERSIBLE SEAMLESS POLYSTYRENE DOORS WITH CUTOUTS 18 GAUGE

- Includes closer reinforcement, appropriate WHI fire label Positive Pressure,  Smoke label.
- STC rating 26, R value 5.24, U value 0.31
- Other locations and sizes are available.

ITEM#	SIZE	DESCRIPTION	LOCK	CUT OUT SIZE
1813V	3068	Vision Lite	C	12 x 12
1818V			MB	
1840V	3070		C	
1844V			MB	
1813NL	3068	Narrow Lite	C	7 x 22
1813N				5 x 35
1840NL	3070			7 x 22
1840N				5 x 35
1813HG	3068	Half Glass	C	24 x 30
1840HG	3070			24 x 32
1840FG	3070	Full Glass	C	24 x 60
1844FG			MB	
1813L1-1212	3068		C	12 x 12
1818L1-1212			MB	
1840L1-1212	3070		C	
1844L1-1212			MB	
1813L1-1812	3068	Louver	C	18 x 12
1818L1-1812			MB	
1840L1-1812	3070		C	
1844L1-1812			MB	
1813L1-2412	3068		C	24 x 12
1818L1-2412			MB	
1840L1-2412	3070		C	
1844L1-2412			MB	



V1212

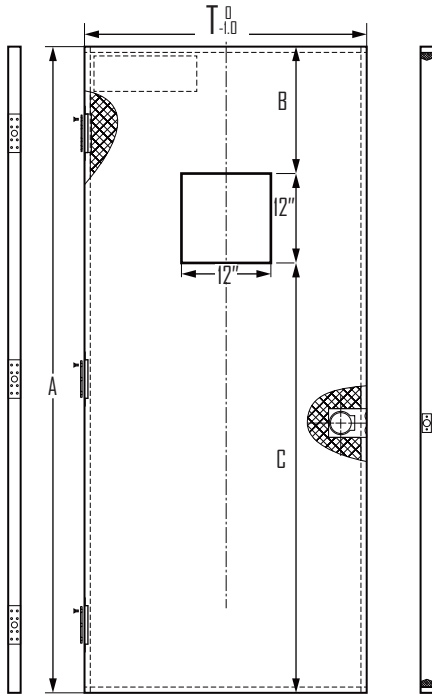

DOOR HEIGHT (A)	B	C
6'8"	11.875"	56.125"
7'0"	15.875"	
8'0"	27.875"	

NL722

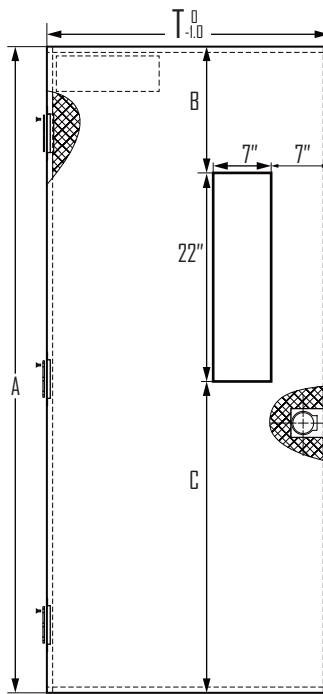

DOOR HEIGHT (A)	B	C
6'8"	11.875"	46.125"
7'0"	15.875"	
8'0"	27.875"	

N535

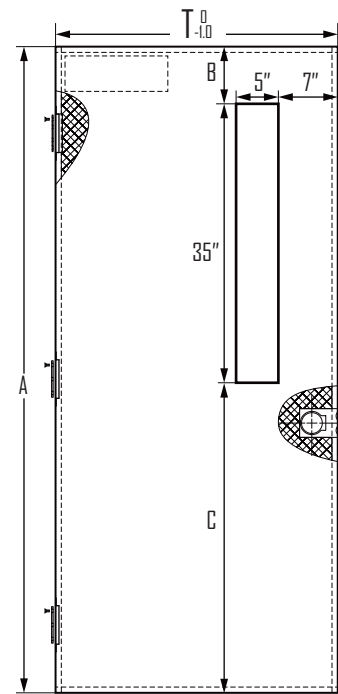

DOOR HEIGHT (A)	B	C
6'8"	2.875"	42.125"
7'0"	6.875"	
8'0"	6.875"	

HG2430 / HG2432

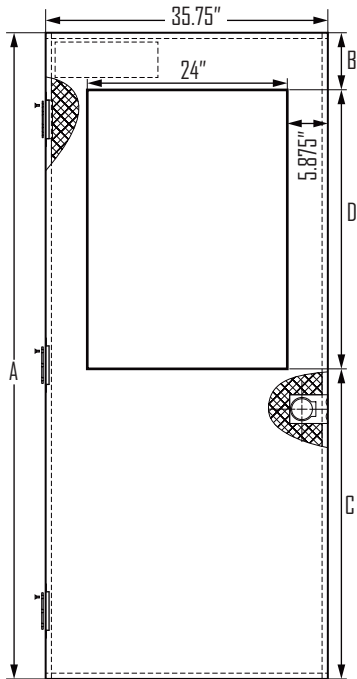

DOOR HEIGHT (A)	B	C	D
6'8"	7.875"	42.125"	30.0"
7'0"	11.875"	54.125"	
8'0"	11.875"		
6'8"	5.875"	42.125"	32.0"
7'0"	9.875"	42.125"	
8'0"	9.875"		

FG2460

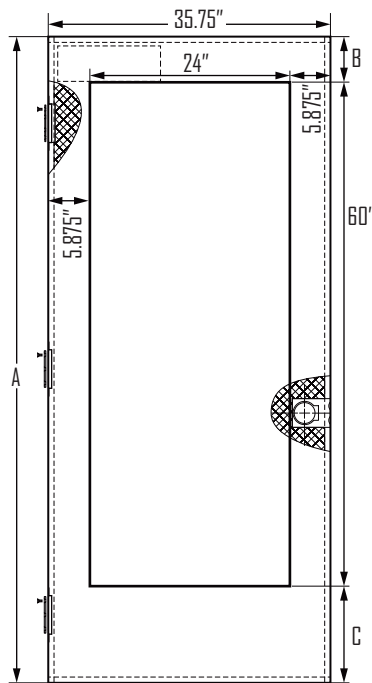

DOOR HEIGHT (A)	B	C
6'8"	4.875"	15.125"
7'0"	8.875"	15.125"
8'0"	8"	28.0"

N535

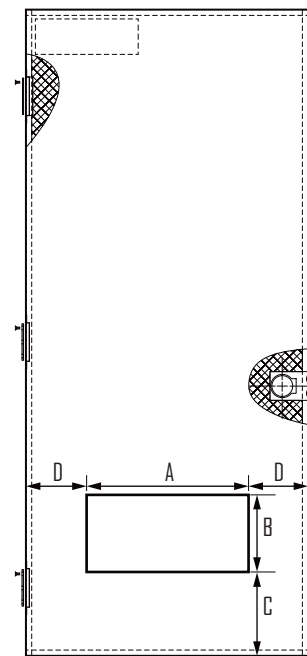

A	B	C	D
12"	12"	13"	EQUAL
18"	12"	13"	EQUAL
24"	12"	13"	EQUAL



# 1800 Series Polystyrene Flush Inactive Doors

FOR ALL MAJOR MANUFACTURERS LOCATION

## 18 GAUGE

- Includes closer reinforcement, fire label WHI 3HR, Positive Pressure **(S)** Smoke label.
- Other locations and sizes are available.

### DOOR MANUFACTURERS CHART

<b>CE</b>	Ceco Location (non handed)
<b>CU</b>	Curries Location (non handed)
<b>REP</b>	Republic Location (non handed)

ALL INACTIVE DOORS ARE PREPARED FOR, AND INCLUDES:

- ASA STRIKE PREP
- MANUAL / AUTO FLUSH BOLT PREP
- LOOSE WRAP AROUND HANDED ASTRAGAL WITH FLUSHBOLT AND ASA PREP

\* To be used for Steel Craft, Amweld and Republic locations.

\*\* To be used for Steel Craft, Amweld locations.

### Inactive Doors

HAND	ITEM#	SIZE
RH	1807 IA	2668
LH		
RH	1826 IA	2868
LH		
RH	CE1813 IA	3068
LH		
RH	1813 IA *	
LH		
RH	CU1813 IA	
LH		
RH	CE1840 IA	3070
LH		
RH	CU1840 IA	
LH		
RH	REP1840 IA	
LH		
RH	1840 IA **	
LH		
RH	1863 IA	3080
LH		
RH	1872 IA	4068
LH		

# 1800 & 1600 Series Polystyrene Flush Doors

PREPARED FOR FULL MORTISE CONTINUOUS HINGE APPLICATION

STOCK REVERSIBLE CORNER SEAM POLYSTYRENE FLUSH DOORS

- Includes closer reinforcement, fire label WHI 3HR, Positive Pressure **(S)** Smoke label.
- 15/32" undercut on door width to fit most major manufacturers continuous hinge prep.

### 18 GAUGE

ITEM#	SIZE	PREP
1813CHI	3068	C
1818CHI		MB
1824CHI		BR
1840CHI	3070	C
1847CHI		BR
1863CHI	3080	C
1862CHI		MB
1864CHI		BR

### 16 GAUGE GALVANIZED

ITEM#	SIZE	PREP
G1608CH	3070	MB
G1611CH		BR
G1649CH	3670	C
G1650CH		MB
G1654CH	4070	C
G1655CH		MB

### 18 GAUGE GALVANIZED

G1849CH	3670	C
G1850CH		MB
G1854CH	4070	C
G1855CH		MB



# 1800 Series Hurricane Tested Florida Approved FL-13624

## COMMERCIAL STEEL SINGLE DOOR INSWING / OUTSWING "IMPACT" (COMPONENT TESTED)

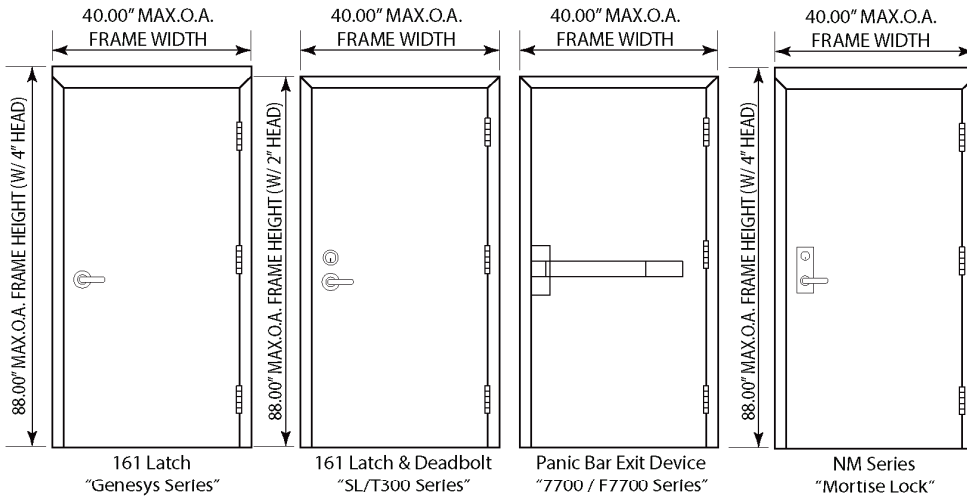

MAX FRAME DIMENSIONS	LOCKTYPE	DESIGN PRESSURE (PSF)			
		INSWING		OUTSWING	
		POSITIVE	NEGATIVE	POSITIVE	NEGATIVE
40.00" x 88.00"	161 LATCH & DEADBLOT "SL/T300 Series"	+55.0	-55.0	+55.0	-55.0
40.00" x 88.00"	161 LATCH "Genesys Series"	+70.0	-70.0	+70.0	-70.0
40.00" x 88.00"	PANIC BAR EXIT DEVICE "7700 / F7700 Series"	N/A	N/A	+70.0	-70.0
40.00" x 88.00"	NM Series "Mortise Lock"	+80.0	-80.0	+80.0	-80.0

## COMMERCIAL STEEL DOUBLE DOOR INSWING / OUTSWING "IMPACT"

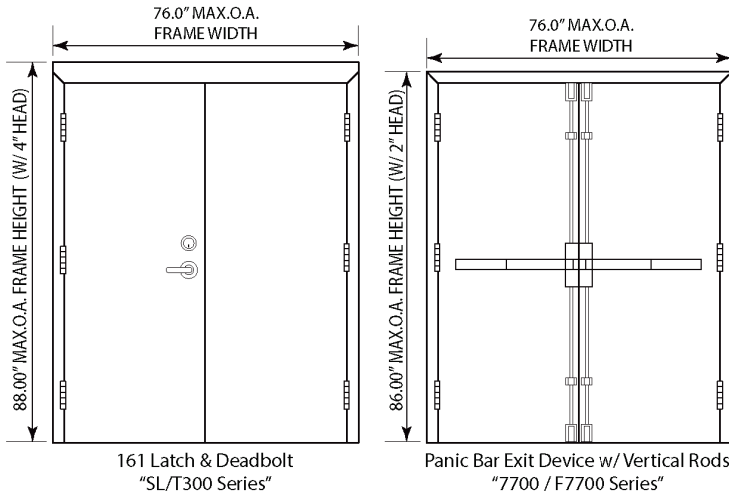

MAX FRAME DIMENSIONS	LOCKTYPE	DESIGN PRESSURE (PSF)			
		INSWING		OUTSWING	
		POSITIVE	NEGATIVE	POSITIVE	NEGATIVE
76.00" x 88.00"	161 LATCH & DEADBLOT "SL/T300 Series"	+55.0	-55.0	-55.0	-55.0
76.00" x 88.00"	PANIC BAR EXIT DEVICE w/ VERTICAL RODS "7700 / F7700 Series"	N/A	N/A	+70.0	-70.0

## COMMERCIAL STEEL DOOR OUTSWING "IMPACT"

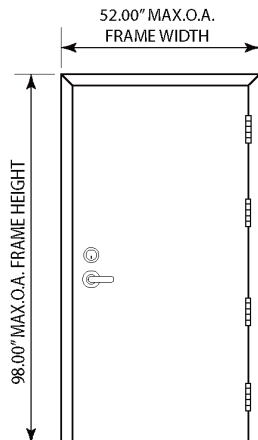

OVERALL FRAME DIMENSIONS	LOCKTYPE	DESIGN PRESSURE (OUTSWING ONLY)	
		POSITIVE	NEGATIVE
52.00" x 98.00"	161 LATCH (CAL-ROYAL)	+80.0	-80.0