

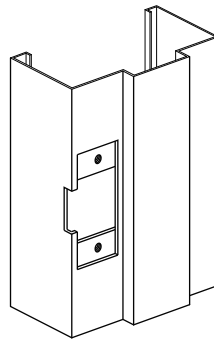

Standard Features

- ◆ 16-Gauge Cold Rolled Steel
- ◆ Unequal Rabbet / 2-inch Face
- ◆ 5/8-inch Stop Height
- ◆ Exact Fit Mitered Corners with Screw Reinforcement Between Head and Jamb Sides
- ◆ 7-Gauge Hinge Reinforcement with Standard / Heavy Duty Adjustment
- ◆ 4-7/8" Universal Strike Preparation
- ◆ Screw Adjusting Compression Anchors on Jamb Side
- ◆ 9/32-inch Silencer Preparation
- ◆ 5-5/8" - 9-3/4" Jamb Depth
- ◆ 1/2 inch Double Returns
- ◆ 20 to 90 Minute Fire Label

Typical Hardware Preparations



2-3/4" CYLINDRICAL STRIKE

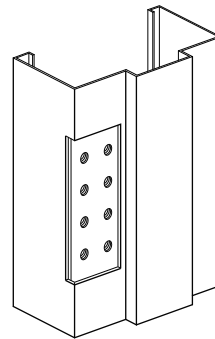

4-1/2" x 4-1/2"
1-3/4" FRAME HINGE PREP

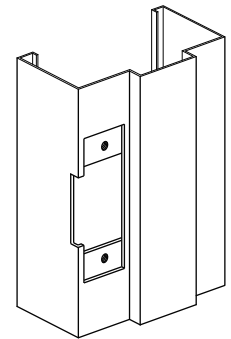

4-7/8" UNIVERSAL STRIKE

Features

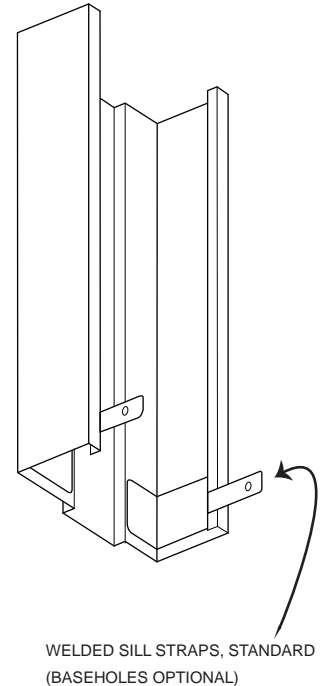
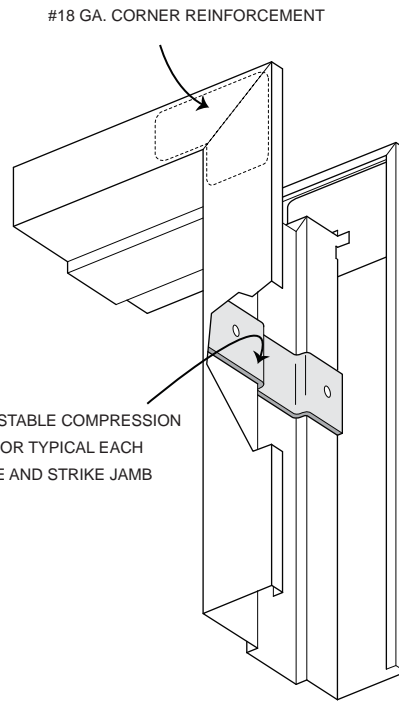

Frame Profiles

