

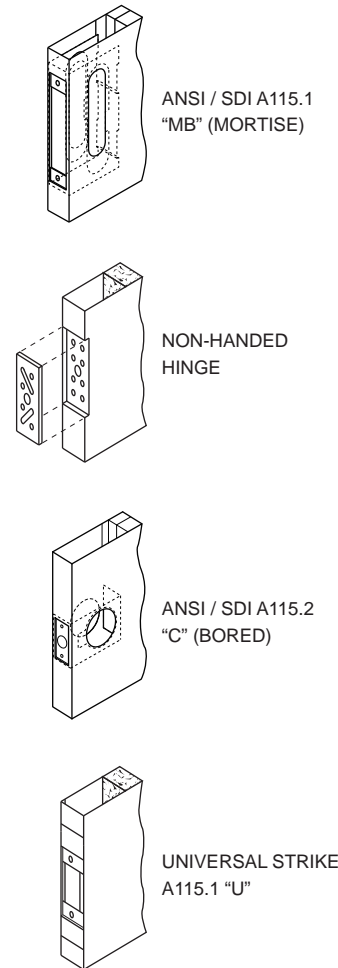

**Standard Features**

- ◆ 1-3/4" Temperature Rise Doors 250° or 450°
- ◆ 18 or 16 Gauge Cold Rolled or Galvanized Steel
- ◆ Seamless Filled Edges
- ◆ Full Body Mineral Core
- ◆ Non- Handed Design
- ◆ 12-Gauge Closer Reinforcement
- ◆ 7-Gauge Hinge Reinforcement- Standard / Heavy Duty
- ◆ 16-Gauge Flush Top Cap - Galvanized
- ◆ 16-Gauge Inverted Bottom Cap - Galvanized
- ◆ Prime Painted Grey Two Part Epoxy Factory Applied, Baked On
- ◆ Standard Lock Preparations Include 161, Fed 86 Edge, Panic Bar Reinforced
- ◆ WHI / ITS up to 3 hour, Positive Pressure and "S" Smoke included
- ◆ Meets or Exceeds Standards for ANSI 250.4 and ANSI 250.8

**Typical Hardware Preparations**



**Sections**

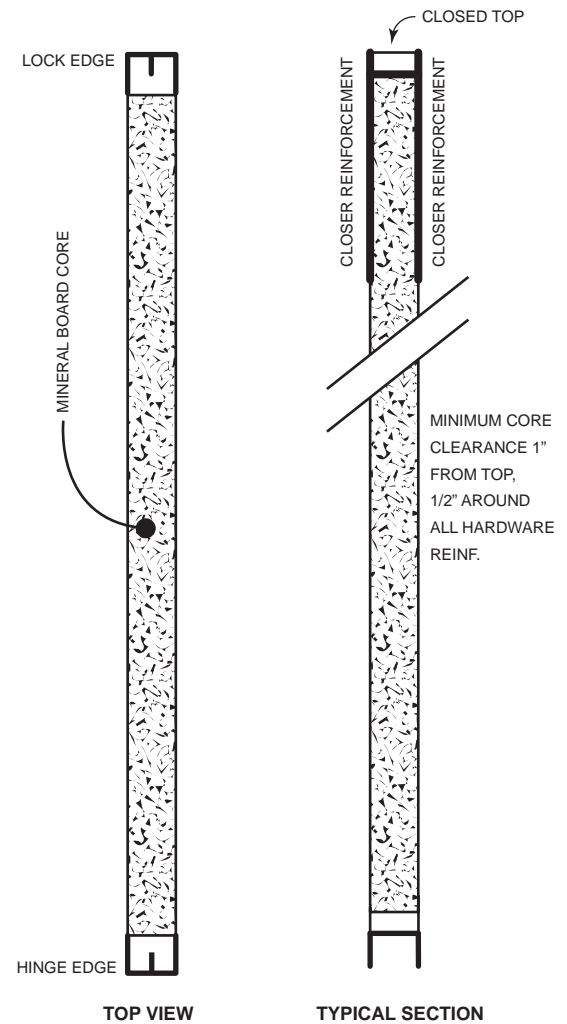

**3 HOUR LABEL STYLES**

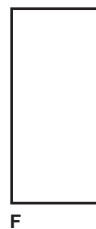

**1-1/2" HOUR LABEL STYLES**

